

## Specifications

Controller current draw: 0.015A, plus lamp current

Operating voltage: 9 - 16 VDC

Control module dimensions: L: 1.75" W: 1.31" H: 0.5"

Control module weight: 1 oz.

Maximum Lamp Current: 6 amps

TS models 3 amps per channel

*This product is protected by US patent 7,928,660.*

Email: [info@skenelights.com](mailto:info@skenelights.com)  
Web page: [www.skenelights.com](http://www.skenelights.com)  
253-277-0408  
Designed and manufactured in the USA

## IQ-250 Family

### Installation and Instruction Manual

### Front Lighting Controllers

more details may be found at:

<https://skenelights.com/photon-blaster-installation--iq-250-series.html>

### Introduction

The IQ-250 intelligent lighting controller is a stand-alone version of the controller used in Skene Lights' Photon Blaster. It adds our unique conspicuity flicker to your own add-on front visibility lights.

The IQ-250-TS model is a dual channel controller that can power extra left and right turn signal lamps or existing turn signals, turning them into bright marker lights. If the existing or add-on turn signals are LEDs, it also provides them with our conspicuity flicker.

The IQ-250 can support any number of lamps with a maximum current draw of 6 amps. The IQ-250-TS model can support two channels (left and right), lamps with a maximum current draw of 3 amps per channel.

### Installation

#### Connect the Controller

With reference to Figure 1 use one of the included blue Positap<sup>®</sup> connectors (Fig 2) to connect the **red** wire from the controller to a switched power source. The current draw is 0.015 amps for the controller plus the current drawn by the attached lamps.

Then twist together the **black** wire from the controller and the ground wires from the attached lamps and connect them to a ground wire on the bike using a blue Positap.

For the IQ-250-TS model (Figure 1a), connect the **yellow** and **green** wires to the wires going to the vehicle's right and left turn signals, respectively, using the red/gray Positap connectors.

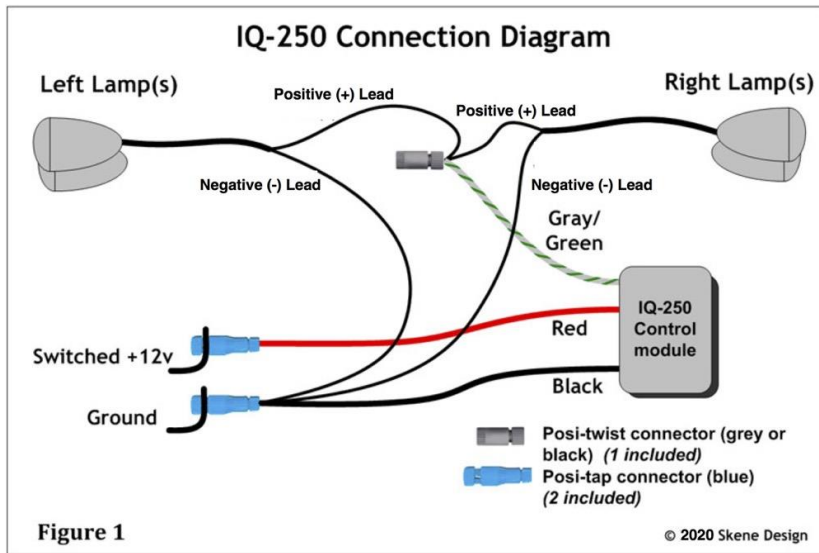

For the IQ-250-A-TS with ALERT! option, connect the blue wire to your brake light or horn wire using the included Posi-lock connector and black extension wire, as shown in Fig 1a.

### Connect the Visibility Lamps

Connect the IQ-250's gray/green wire to the visibility lamp's positive lead using the Posi-twist™ connector as shown in Figure 1. Instructions for using the Posi-tap and Posi-twist connectors are shown in Figure 2.

For TS model with the turn signal option, connect the controller's gray/green wire to the left lamp and the gray/yellow wire to the right lamp as shown in Figure 1a.

**Note:** The IQ-250-TS can also convert your vehicle's turn signal lamps to bright visibility lights. See Figure 1b on the following web page for a wiring diagram of this option:

[sknelights.com/photon-blaster-installation-iq-250-series.html](http://sknelights.com/photon-blaster-installation-iq-250-series.html)

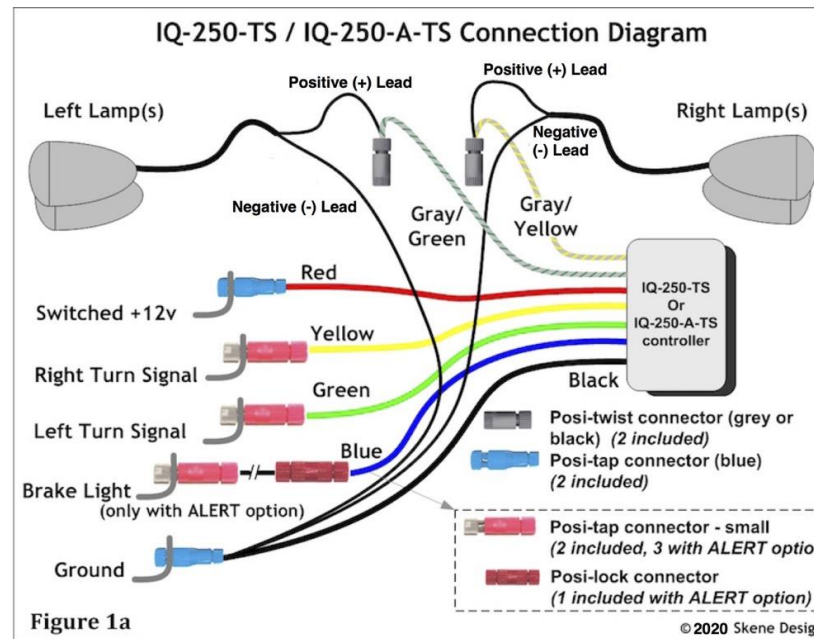

### Operation

#### Turn Signal (TS model only)

The IQ-250-TS model turns the attached visibility lamps into supplementary turn signals. If your bike has 4-way flashers, the lamps will track these. To ensure that your motorcycle adheres to local vehicle regulations, the vehicle's original turn signals should be retained.

#### ALERT! option (A-TS models only)

To activate the ALERT! feature, tap the brakes or horn twice within two seconds. The visibility lamps will respond with a very effective alerting flash sequence to signal traffic in front of you of your presence.

### Programming Details

The IQ-250 has two different modes of operation. The default mode has conspicuity flicker enabled. In the optional, non-modulated mode, the lamps maintain a constant brightness. The average brightness of the lamps in each mode is the same, but the conspicuity flicker makes your motorcycle much more noticeable. You can read more about Skene Lights' unique conspicuity flicker here:

[sknelights.com/conspicuity-flicker](http://sknelights.com/conspicuity-flicker)

Note: Conspicuity flicker will only be visible if the supplementary lamps are LEDs. Traditional bulbs have too slow a response time for the flicker to be noticeable.

The IQ-250 can quickly and easily be switched from one operating mode to the other. To change modes, simply turn the ignition on then off three times, leaving it on for no longer than one second each time. When you turn the ignition on again, the unit will be reprogrammed to operate in the alternate mode.

The operating mode is saved and is only changed when the above process is followed.

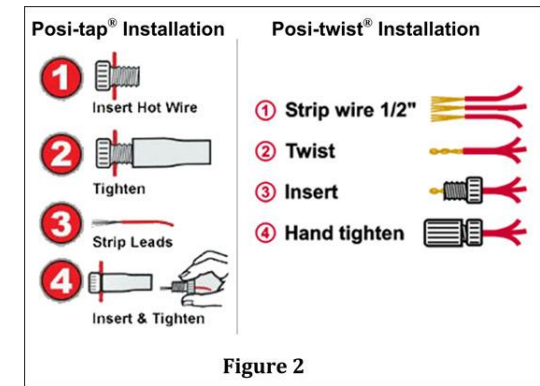

*Note:* Depending upon local regulations, the user may want to switch the unit to the non-modulated mode.